

# HP HOME PRESSURE SYSTEMS WITH TORRIUM®

Model Numbers: HP45-05T, HP65-06T & HP85-08T

DEPEND ON  
**DAVEY**

**WATER PRODUCTS**



## HP PRESSURE SYSTEM

### PRODUCT DESCRIPTION

Robust & compact, multi stage centrifugal pumps with Torrium® constant flow control and loss of prime device for automatic water pressure. Designed for medium to large size, single storey homes.

### APPLICATIONS

Ideal for pumping clean, non-volatile liquids without fibres or solids in such applications as :-

- Household water supply
- Irrigation
- Water transfer
- Washing systems
- Pressure boosting

### FEATURES & BENEFITS

#### SYSTEM

The HP Pressure System consists of a HP pump fitted with a Torrium® controller. The Torrium® is supplied connected electrically to the HP pump motor for:

- Easy non-tradesmen installation and assembly
- Positive safety under varied weather conditions

The combination of the high pressures supplied by the multistage HP pump and constant flow control provided by the Torrium® enables consumers to enjoy the benefits of a strong comfortable shower from a pump that does not cycle plus the reliability of adaptive technology.

The complete HP Pressure System is compact and quiet providing for:

- Easy installation, especially where space is at a premium
- Non-intrusive operation, for consumer enjoyment

All parts of the entire system that are in contact with the water are manufactured from safe, corrosion resistant materials for:

- Consumer confidence that their water supply will be as good coming out as it was going into the system
- Ability to use the HP pressure system on a variety of water qualities

Compliance with the strict requirements of ISO 9001.2000 quality standards ensures consistency of quality of the system.

### OPERATING LIMITS

Maximum system pressure*	450kPa
Capacities to	140 lpm
Maximum total head	33m
Maximum suction head	6m
Maximum ambient temperature	50°C
Maximum water temperature	50°C
Minimum water temperature	1°C

Torrium® cut-in pressure is normally 80% of the pumps last shut-off head.



# TECHNICAL SPECIFICATIONS

## FEATURES & BENEFITS continued...

### PUMP

Multistage, closed vane impellers with full length "D" drives, provide :-

- Superior reliability when pumping corrosive water
- Easy assembly and servicing

Corrosion resistant 304 stainless steel pump shaft and casing for long service life.

Patented floating impeller neck rings provide :-

- High efficiency
- Quieter pump operation

High quality, low-drag mechanical shaft seal for long life and reliable starting.

### MOTOR

The Davey manufactured TEFC motor has an IP55 enclosure providing:

- Excellent corrosion resistance
- High levels of resistance to dust and rain

All HS pump motors are class F insulation rating and have higher than normal ambient temperature ratings of 50°C, providing for longer life, improved tolerance to voltage variations and peace of mind, even on the hottest days.

All HS pump motors are single phase permanently split capacitor design for:-

- Reliable starting even in low voltage circumstances
- Superior frequent starting performance

Single phase motors are protected against both high operating temperatures and high current by a built in, automatically resetting thermal overload.

Double contact C3-HTG sealed bearings for quieter running and longer life.

Corrosion resistant feet on motor shell, include three point bolt-down facility.

Standard models are 220/240 volt, 50Hz, single phase. HS models in 60Hz 110/115 volt and 220/230 volt single phase available on request.

### TORRIUM® CONTROLLER

Torrium® starts pump on pressure drop and stops pump on low flow (~2 lpm), thus reducing pump cycling for constant and even water pressure.

Torrium® measures the pump shut off head each time the pump stops, and sets the cut-in pressure at 80% of shut-off head, so that the consumer is unlikely to notice any pressure change when the pump is switched on. Torrium® adapts each time the pump stops, thus allowing the system to accommodate variations in pump performance or site conditions.

Torrium® has a simple indicator and fault LED system. Red constant means that the system is in standby. Green constant means the pump is running.

An Amber constant LED indicates that the system has gone to Cistern Fill mode. Cistern Fill mode is activated when the Torrium® detects frequent short cycling, such as may be encountered with a very slow filling toilet cistern. The Torrium® will then ensure the pump continues to operate for at least 2 minutes.

Torrium® stops the pump in "loss of prime" circumstances and activates the loss of prime LED indicator sequence (red LED single flash per sequence), thus:-

- Protecting the pump from dry run damage
- Helps identify installation faults

When the Torrium® detects "loss of prime" it waits 5 minutes then goes into auto retry mode, whereby it will restart the pump to see if prime can be re-established automatically. Auto retry occurs at 5 minutes, 30 minutes, 1 hour, 2, 4, 8, 16 and 32 hours. Torrium® will also retry if it detects flow through the system (eg from mains water pressure returning).

If Torrium® detects excessive electrical current, such as when a the pump motor is subjected to lock rotor or when someone tries to manually override the Torrium® by holding in the prime button, the Torrium® will shut the pump down and indicate 2 red flashes per sequence.

Should the Torrium® detect low incoming voltage (below 180 volts) it will allow the pump to continue to operate if possible, but it will flash two red flashes per sequence over the green run LED.

Water over-temperature cut-out fail safe protection, provides a second level of protection against loss of prime and / or closed head operation and / or repetitive cycling for added security and longer life. In the event of the Torrium® detecting water over-temperature above 70°C it will shut the pump down and flash 3 red LED flashes per sequence. Once the water temperature has dropped to below 60°C, the Torrium® will allow the pump to restart.

Torrium® also detects slow leaks and attempts to overcome the short run times such leaks can cause by dropping temporarily the cut-in pressure to 50% of the last shut-off head. Torrium® will return to 80% cut-in pressure after 100 cycles or if a manual reset is initiated.

Torrium® has no moving parts in the waterways:-

- No parts to jam means improved reliability
- Less reduction of pump performance
- Reliable usage with varying water quality

Corrosion and scale resistant flow and pressure sensors mounted on a high grade titanium plate. Special anti scaling electronic functions allow Torrium® to be used with water of varying quality.

Torrium® has an inbuilt spring loaded pressure tank, overcoming the need for regular pressure vessel air charging and checking.

Right angle discharge rotatable around full 360°, with optional pressure tank mounting position on top, facilitates:-

- Easier installation and connection to plumbing
- Use with a choice of optional pressure tank sizes

All models come with a 2 metre power lead fitted with a 3 pin Australian plug.

# TECHNICAL SPECIFICATIONS

## MATERIALS OF CONSTRUCTION

PART	MATERIAL
<b>PUMP</b>	
Impellers	Glass filled polycarbonate
Lock nut	304 stainless steel
Pump casing	304 stainless steel
Pump backplate	304 stainless steel
Pump shaft	303 stainless steel
Neckrings	Polypropylene + teflon
Seal ring (stationary)	Ceramic
Seal ring (rotating)	Carbon (synthetic)
Seal spring	304 stainless steel
O-rings	Nitrile rubber
Stage body	Glass filled noryl
Suction check valve	
Body	Polypropylene
Spring	304 stainless steel
Seal	Nitrile
Stage spacer	Glass filled nylon (3 stage models)
Priming plug	Glass filled noryl
Motor shell	Marine grade aluminium
Lantern/DE endshield	Marine grade aluminium
Shell & lantern finish	Baked polyester
<b>TORRIUM®</b>	
Housing	Glass fibre reinforced nylon
Pressure tank diaphragm	Santoprene 87
Pressure tank springs	Molybond coated tempered steel
Sensor plate	High grade TITANIUM
Flange adaptor	Glass fibre reinforced nylon
Locking nut	Glass fibre reinforced nylon
O-rings	Nitrile

## HYDRAULIC PERFORMANCE

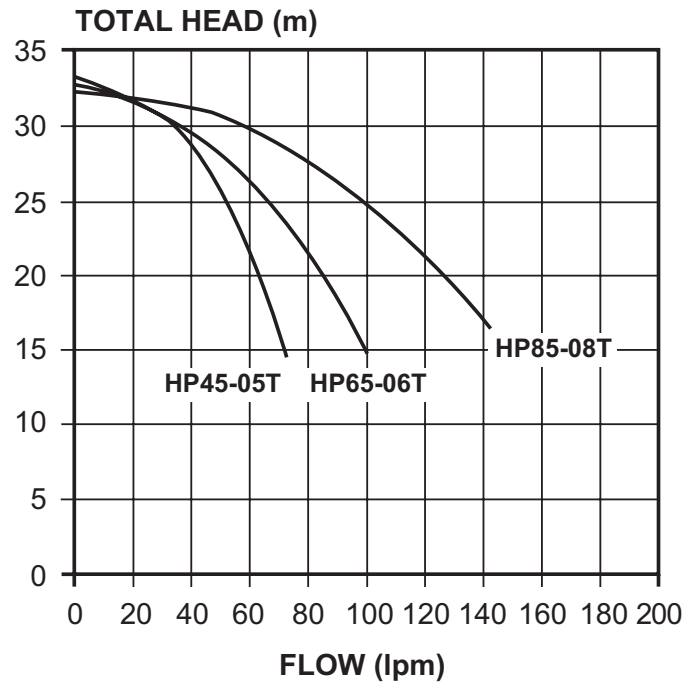

## ELECTRICAL DATA

	HP45-05	HP65-06	HP85-08
Supply voltage	220-240V ±6%		
Supply frequency	50Hz		
Phase	Single		
Speed	2850rpm		
Full load current	3.4A	3.8A	5.1A
Locked rotor current	12.0A	12.0A	12.0A
Input power (P <sub>1</sub> )	0.77kW	0.9kW	1.14kW
Output power (P <sub>2</sub> )	0.55kW	0.6kW	0.8kW
Enclosure class	IP55		
Insulation class	Class F		
Starting	P.S.C.		

Note: All performance at 240V 50Hz

	TORRIUM®
Voltage	220V-240V ± 10%
Phase	Single
Hz	50 / 60
IP rating	56
Maximum load current	10A
Maximum motor size*	1.8kW
Surge protection	Varistor

## INSTALLATION & PRIMING

- Installations with suction lift require a good quality foot valve to avoid loss of prime - remove in-built check valve.
- To prime, fill pump body and suction line through priming plug hole located above suction inlet and replace plug.

# TECHNICAL SPECIFICATIONS

## DIMENSIONS

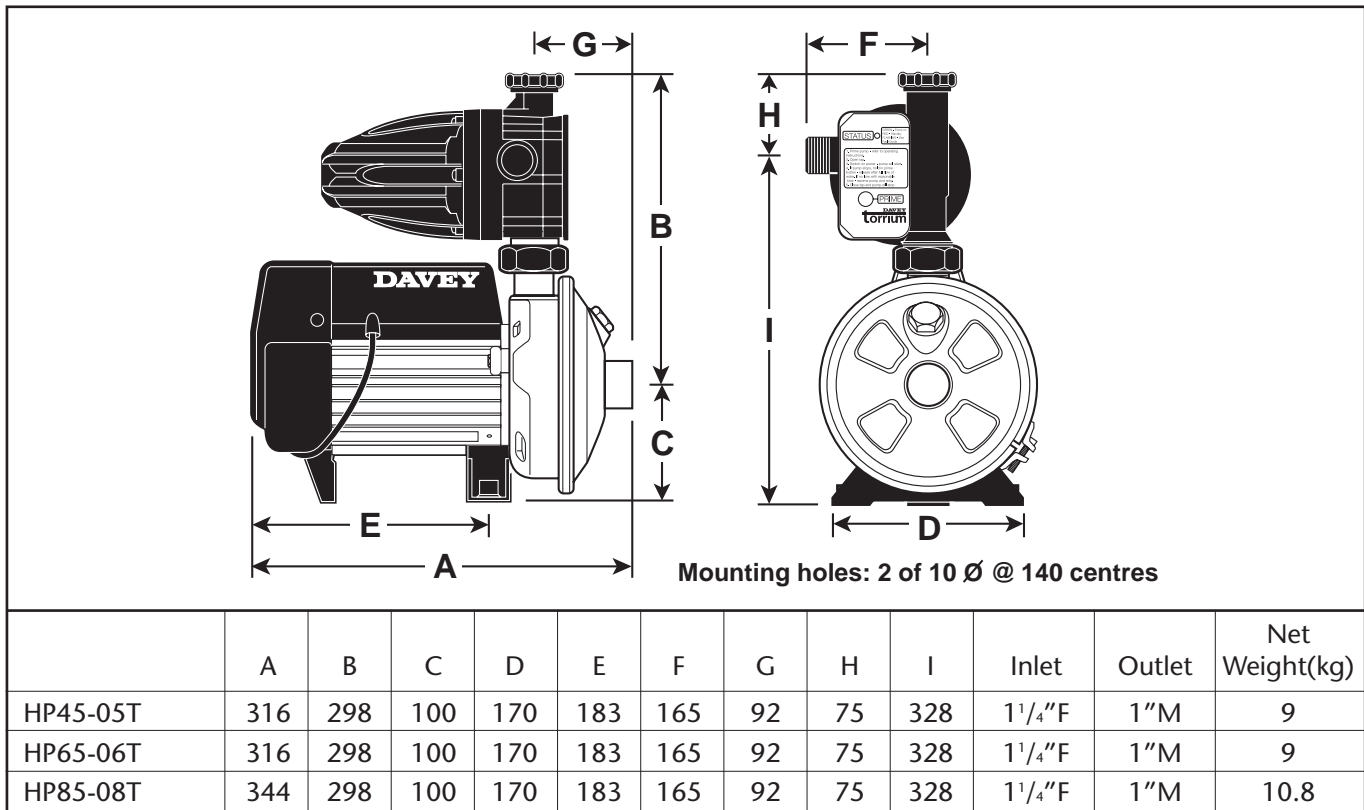

All dimensions in mm unless otherwise stated.

This literature is not a complete guide to product usage. Further information is available from your Davey dealer, Davey Customer Service Centre and from the relevant product Installation and Operating Instructions. This data sheet must be read in conjunction with the relevant product Installation and Operating Instructions and all applicable statutory requirements. Product specifications may change without notice. © Davey and Torrium are registered trademarks of Davey Products Pty Ltd. © Davey Products Pty Ltd 2005.



Visit Davey on-line for further information  
[www.davey.com.au](http://www.davey.com.au)

DEPEND ON  
**DAVEY**

**WATER PRODUCTS**

### Davey Products Pty Ltd

Member of the GUD Holdings Ltd Group

**ABN 18 066 327 517**

#### Head Office and Manufacturing

6 Lakeview Drive,  
 Scoresby, Australia 3179  
 Ph: +61 3 9730 9222  
 Fax: +61 3 9753 4100  
 Website: [www.davey.com.au](http://www.davey.com.au)

#### Customer Service Centre

Ph: 1300 367 866  
 Fax: 1300 369 119  
 E-mail: [sales@davey.com.au](mailto:sales@davey.com.au)

#### Interstate Offices

Sydney - Brisbane - Adelaide  
 Perth - Townsville

### International

6 Lakeview Drive,  
 Scoresby, Australia 3179  
 Ph: +61 3 9730 9121  
 Fax: +61 3 9753 4248  
 E-mail: [export@davey.com.au](mailto:export@davey.com.au)

### Germany

Kantstrasse 47,  
 04275 Leipzig  
 Ph: +49 341 301 0412  
 Fax: +49 341 301 0413  
 E-mail: [akrenz@daveyeurope.com](mailto:akrenz@daveyeurope.com)

### New Zealand

2 Rothwell Avenue,  
 North Harbour, Auckland 1330  
 Ph: +64 9 914 3680  
 Fax: +64 9 914 3685  
 Website: [www.daveynz.co.nz](http://www.daveynz.co.nz)  
 E-mail: [sales@daveynz.co.nz](mailto:sales@daveynz.co.nz)

### USA

**Davey Pumps Inc.**  
 1005 N. Commons Drive  
 Aurora, Illinois 60504  
 Ph: +1 630 898 6976  
 Fax: +1 630 851 7744  
 Website: [www.daveyusa.com](http://www.daveyusa.com)  
 E-mail: [sales@daveyusa.com](mailto:sales@daveyusa.com)